

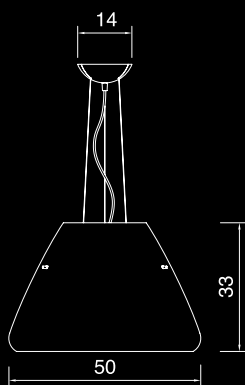

AVMazzega *Preview 2009*

Forme C

Designer: Christophe Pillet

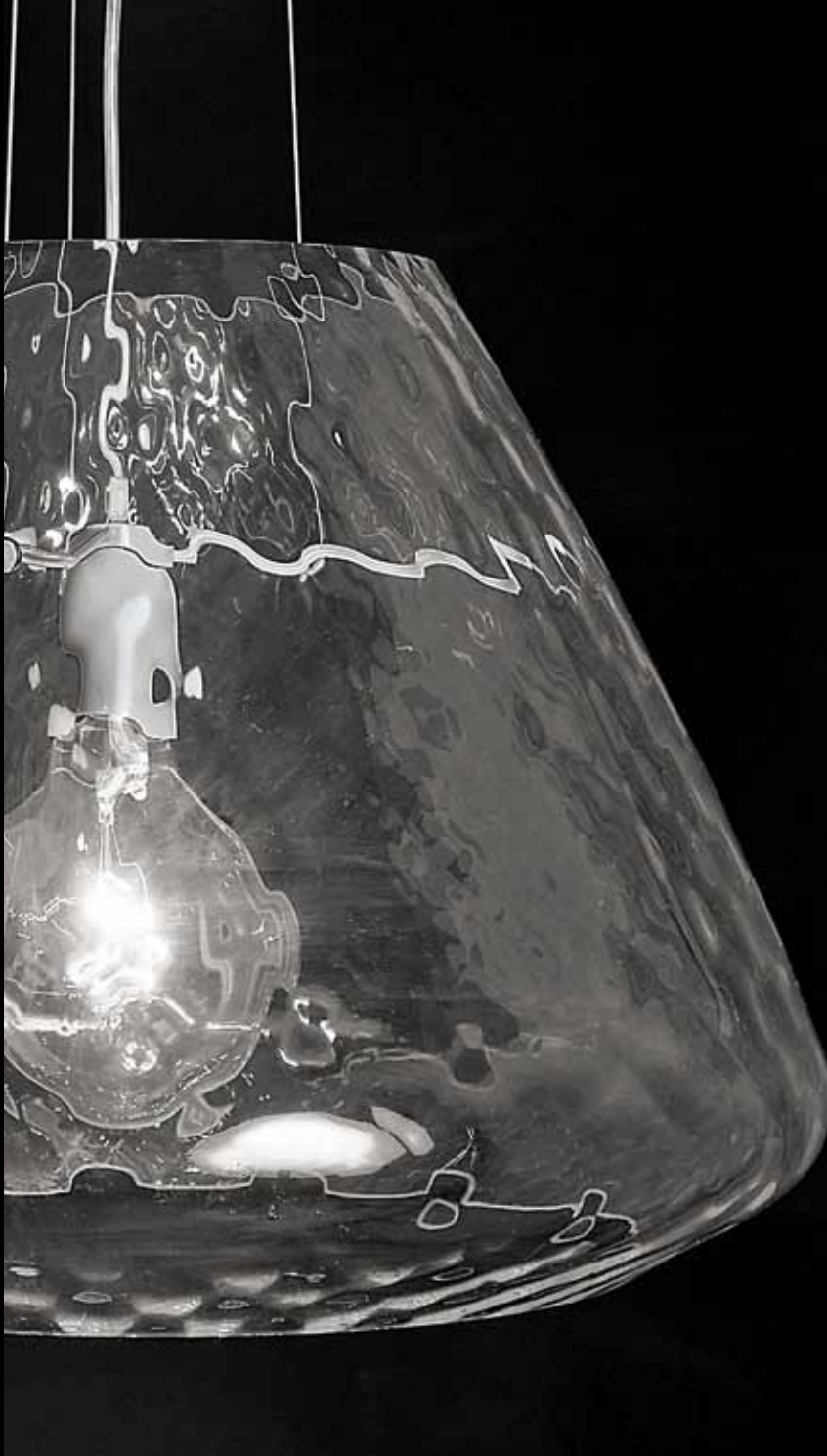

SO 3125

Sospensione in vetro soffiato, lavorato a mano

Struttura: metallo cromato

Colore diffusore: cristallo balloton, bianco con filigrana nera



Hand-crafted glass hanging lamp

Frame: chromed metal

Glass diffuser color: "balloton" crystal, white with internal black decorations

Classe II

1 E27 x max 100W 230V



Energy saving



Argo

Designer: Marturano & Franzin

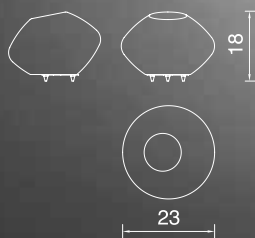



TA 4086

Lampada da comodino in vetro soffiato
Struttura: metallo verniciato grigio grafite
Colore diffusore: bianco striato



Blown glass table lamp
Frame: graphite gray painted metal
Glass diffuser color: striped white

Classe II 1 E14 x max 60W 230V 

 Energy saving

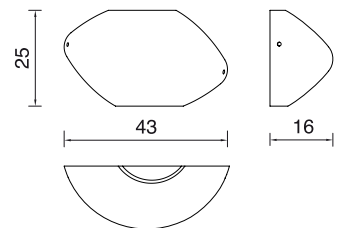
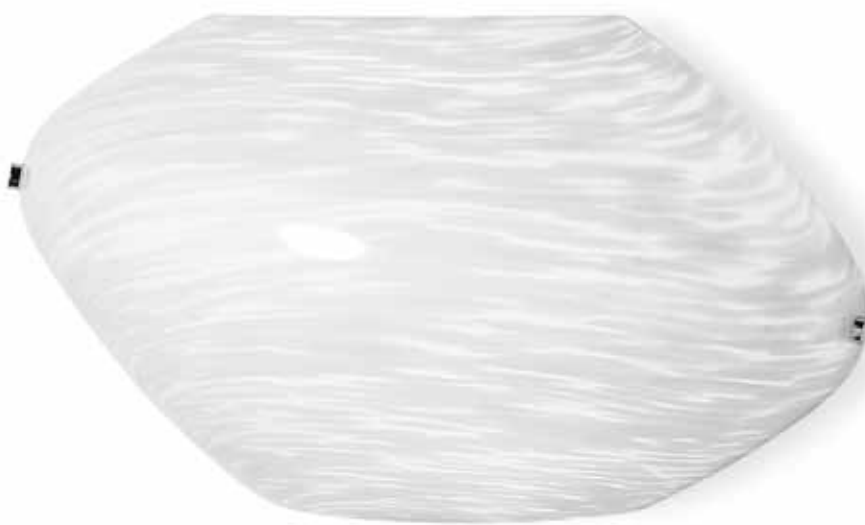

Applique in vetro soffiato
Struttura: metallo verniciato bianco
Colore diffusore: bianco, bianco striato, rosso striato

AP 1099

Blown glass wall lamp
Frame: white painted metal
Glass diffuser color: white, striped white, striped red

 Energy saving

 1 E27 x max 100W 230V Classe II

Mobile

Designer: Jean Marie Massaud

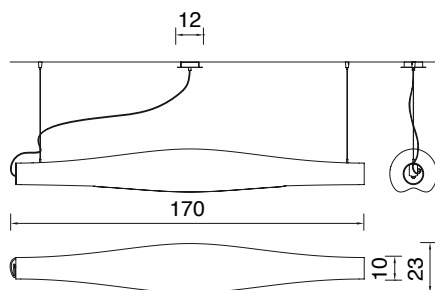

SO 3126

Sospensione in vetro soffiato
Struttura: metallo cromato
Colore diffusore: bianco



Blown glass hanging lamp
Frame: chromed metal
Glass diffuser color: white

Classe I 2 T5 x max 80W 230V

Energy saving

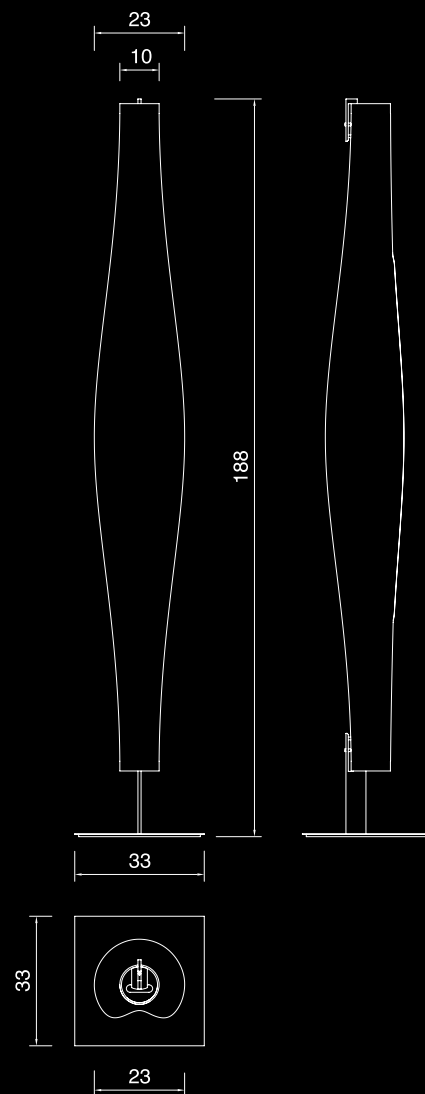

Lampada da terra in vetro soffiato
Struttura: metallo verniciato bianco
Colore diffusore: bianco

TE 5048

Blown glass floor lamp
Frame: white painted metal
Glass diffuser color: white

 Energy saving

 2 T5 x max 80W 230V Classe I

White

Designer: M & M

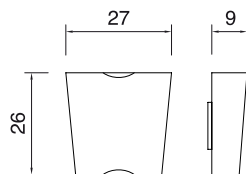

AP 1101

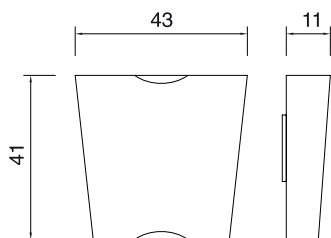

AP 1102

Applique in vetro soffiato
Struttura: metallo nichelato e satinato
Colore diffusore: bianco acidato

Blown glass wall lamp
Frame: brushed nickel plated metal
Glass diffuser color: white satin

Classe II 2 E14 x max 60W 230V (AP 1101)
Classe II 2 E27 x max 100W 230V (AP 1102)



 Energy saving

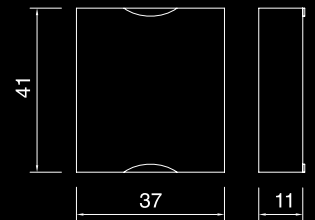
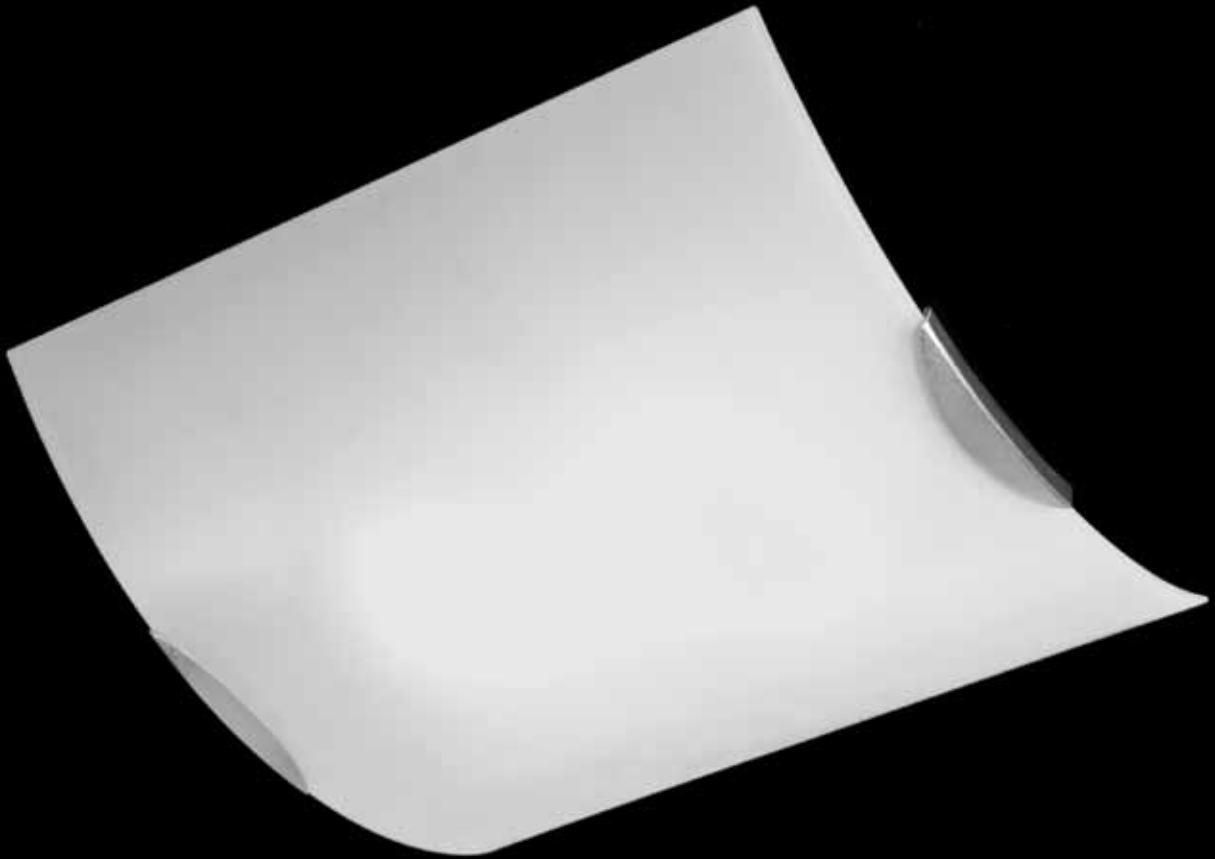

Plafoniera in vetro soffiato
Struttura: metallo nichelato e satinato
Colore diffusore: bianco acidato

PL 2061

Blown glass ceiling lamp
Frame: brushed nickel plated metal
Glass diffuser color: white satin

 Energy saving

 2 E27 x max 150W 230V Classe II

Frisbee

Designer: Christophe Pillet

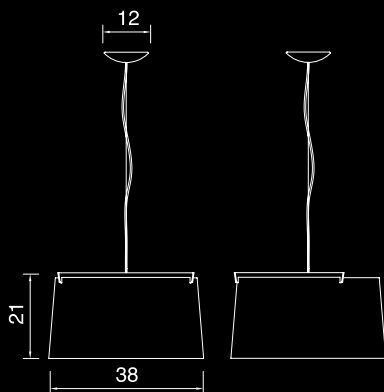

SO 3127

Sospensione in vetro soffiato
Struttura: metallo verniciato bianco
Colore diffusore: bianco acidato

Blown glass hanging lamp
Frame: white painted metal
Glass diffuser color: white satin

Classe II 3 E27 x max 75W 230V 

 Energy saving

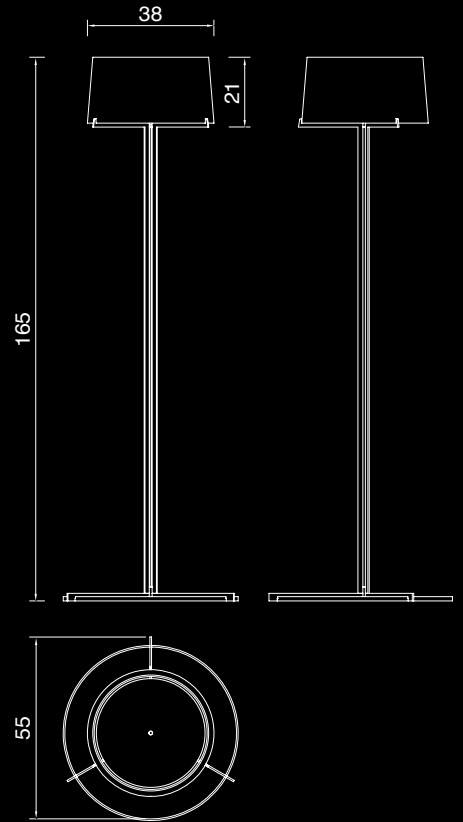
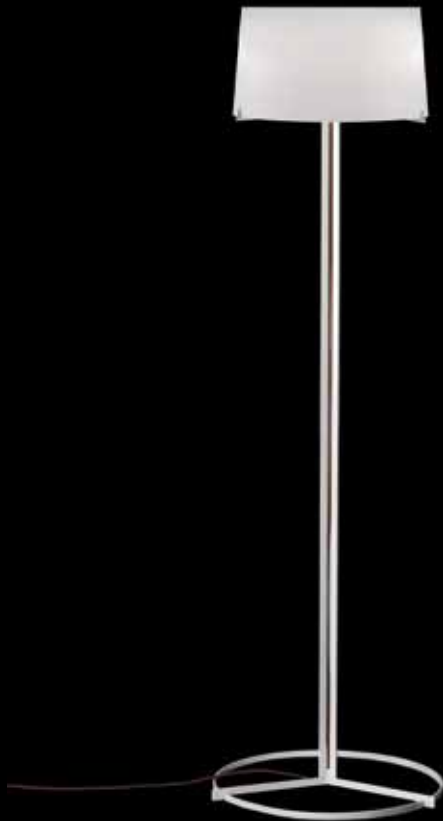

TE 5049

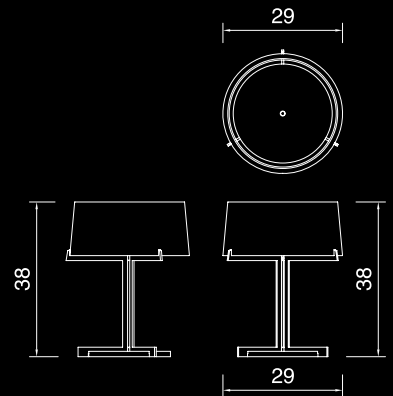



TA 4087



Lampade da terra (TE 5049) e da tavolo (TA 4087) in vetro soffiato
 Struttura: metallo verniciato bianco
 Colore diffusore: bianco acidato

Blown glass floor lamp (TE 5049) and table lamp (TA 4087)
 Frame: white painted metal
 Glass diffuser color: white satin

 Energy saving

 3 E27 x max 75W 230V (TE 5049)
 3 E14 x max 60W 230V (TA 4087)

Classe II
 Classe II

Cocco

Designer: M & M

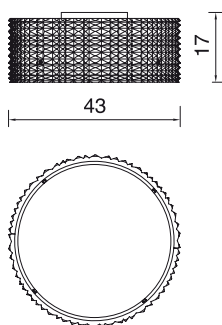

PL 2062

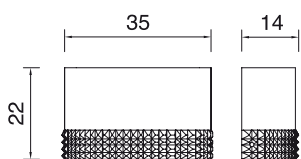

AP 1100

Plafoniera (PL 2062) e applique (AP 1100) in vetro lavorato a piastra
Struttura: metallo verniciato bianco
Colore vetro: cristallo
Paralume in tessuto: avorio



Hand-crafted glass ceiling lamp (PL 2062) and wall lamp (AP 1100)
Frame: white painted metal
Glass color: crystal
Fabric shade: ivory

Classe II 3 E27 x max 75W 230V (PL 2062)
Classe II 1 E27 x max 100W 230V (AP 1100)



 Energy saving

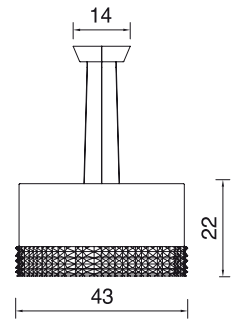

SO 3128

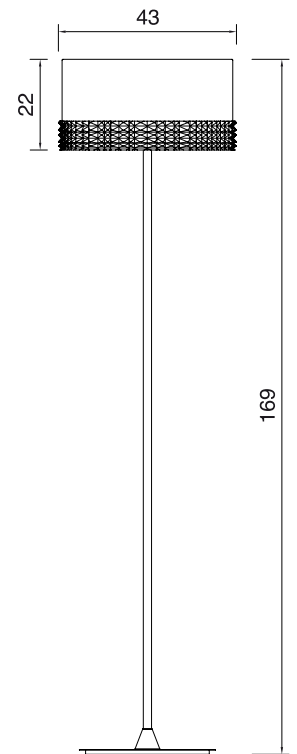

TE 5050

 Sospensione (SO 3128) e lampada da terra (TE 5050) in vetro lavorato a piastra
 Struttura: cromo
 Colore vetro: cristallo
 Paralume in tessuto: avorio

Hand-crafted glass hanging lamp (SO 3128) and floor lamp (TE 5050)
 Frame: polished chrome
 Glass color: crystal
 Fabric shade: ivory

 Energy saving

 3 E27 x max 75W 230V (SO 3128, TE 5050)

Classe II



Frou Frou

Designer: Gordon Guillaumier

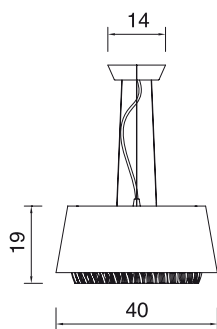

10007/S3

Sospensione con vetro lavorato a mano
Struttura: cromo
Colore vetro: cristallo
Paralume: metallo verniciato nero, interno bianco



Hanging lamp with hand-crafted glass
Frame: polished chrome
Glass color: crystal
Shade: black painted metal, white inside

Classe I 3 E14 x max 60W 230V 

 Energy saving

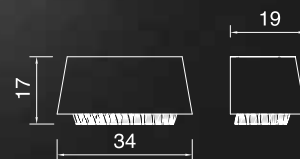
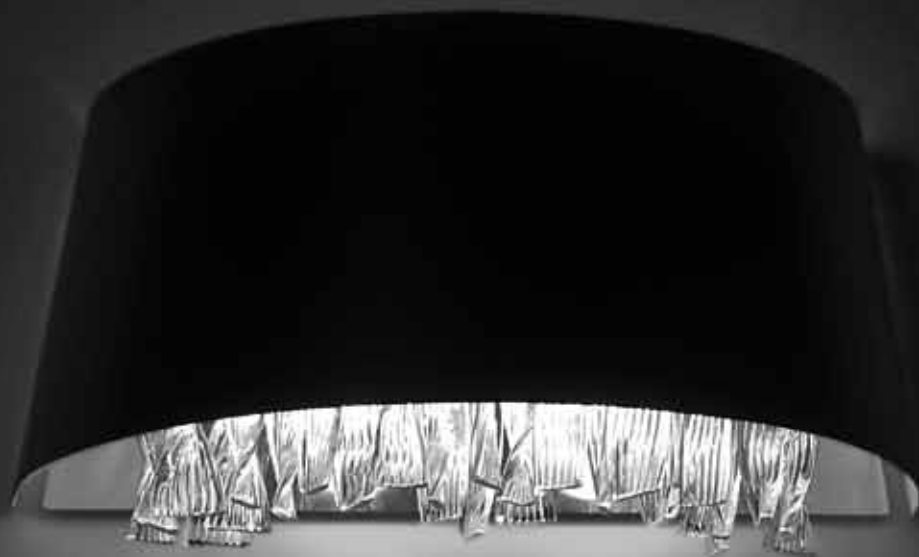

Appliche con vetro lavorato a mano
Struttura: cromo
Colore vetro: cristallo
Paralume: metallo verniciato nero, interno bianco

10007/A2

Wall lamp with hand-crafted glass
Frame: polished chrome
Glass color: crystal
Shade: black painted metal, white inside

 Energy saving

 2 E14 x max 60W 230V Classe I

Frou Frou

Designer: Gordon Guillaumier

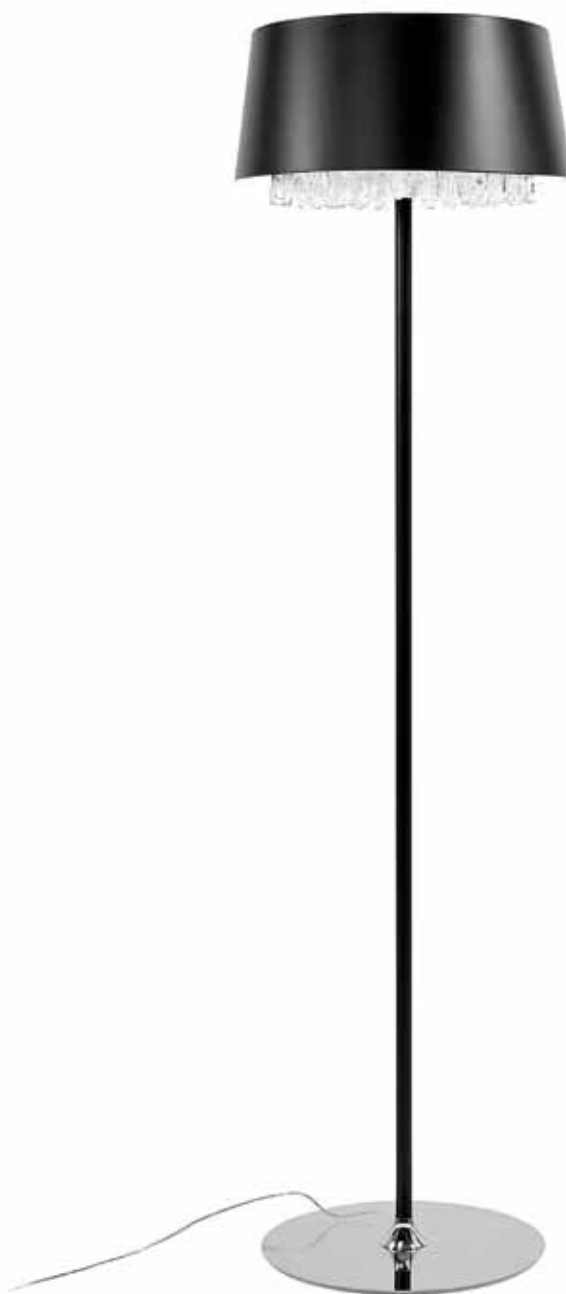
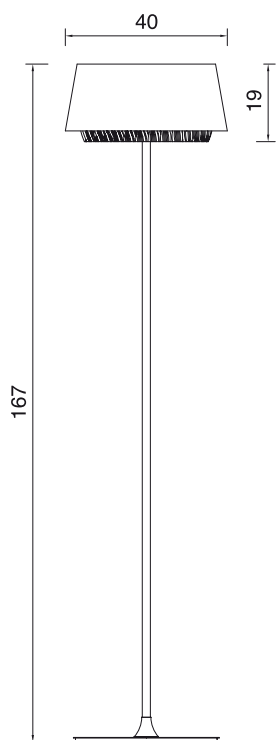

10007/TE

Lampada da terra con vetro lavorato a mano
Struttura: base cromo, stelo verniciato nero
Colore vetro: cristallo
Paralume: metallo verniciato nero, interno bianco

Floor lamp with hand-crafted glass
Frame: chromed metal base, black painted stem
Glass color: crystal
Shade: black painted metal, white inside



Classe I 3 E14 x max 60W 230V 

 Energy saving

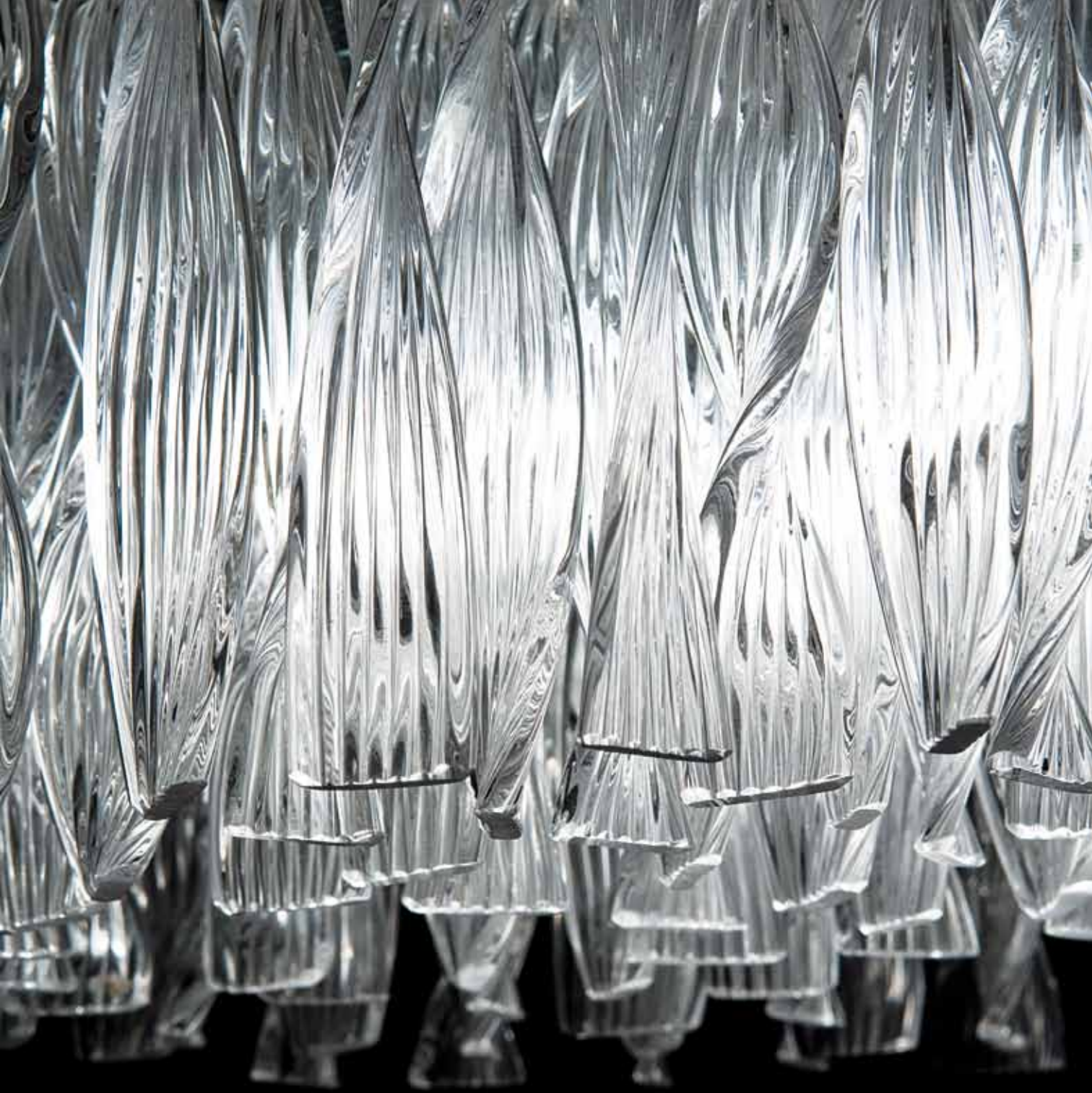

Zante

Designer: Nigel Coates

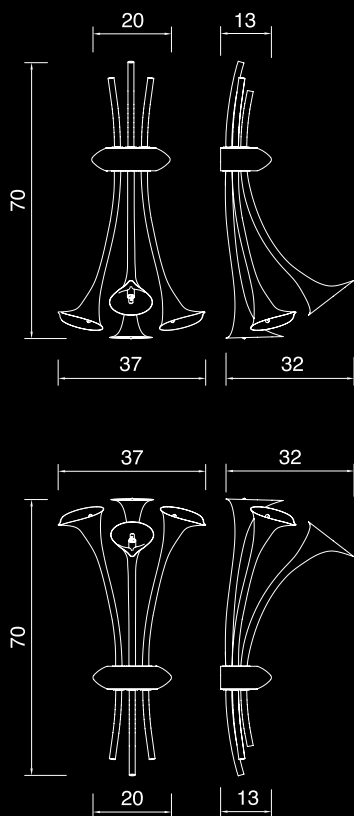

10002/A4

Applique veneziano lavorato a mano
Struttura: metallo cromato
Colore vetro: bianco, cristallo, ambra incamiciato bianco



Hand-crafted glass venetian wall lamp
Frame: polished chrome
Glass color: white, crystal, amber in milk glass

Classe II 4 G9 x max 25W 230V



Curiosity Cabinet

Designer: Jean Marie Massaud

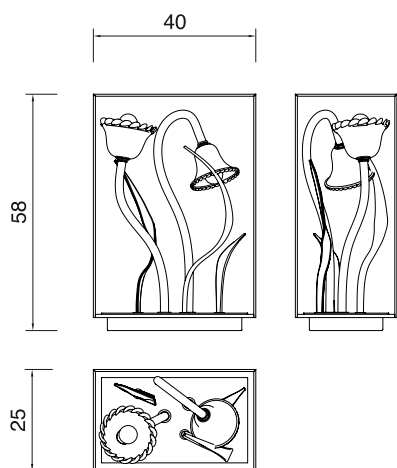

10003/T2

Lampada da tavolo in vetro cristallo fumé con elementi di lampadari veneziani
Struttura: metallo nickel nero
Colore: cristallo, rosso, cristallo/oro



Crystal smoked glass table lamp with venetian chandelier elements
Frame: polished black nickel
Glass color: crystal, red, crystal/gold

Classe I 2 E14 x max 40W 230V 

 Energy saving

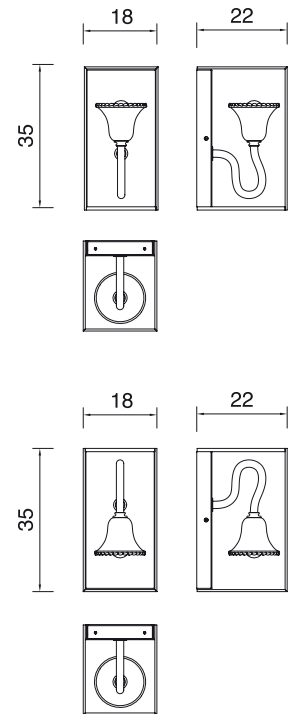

Applique in vetro cristallo fumé con elementi di lampadari veneziani
 Struttura: metallo nickel nero
 Colore: cristallo, rosso, cristallo/oro

10003/A1

Crystal smoked glass wall lamp with venetian chandelier elements
 Frame: polished black nickel
 Glasscolor: crystal, red, crystal/gold

 Energy saving

 1 E14 x max 40W 230V Classe I

Dandy

Designer: M & M

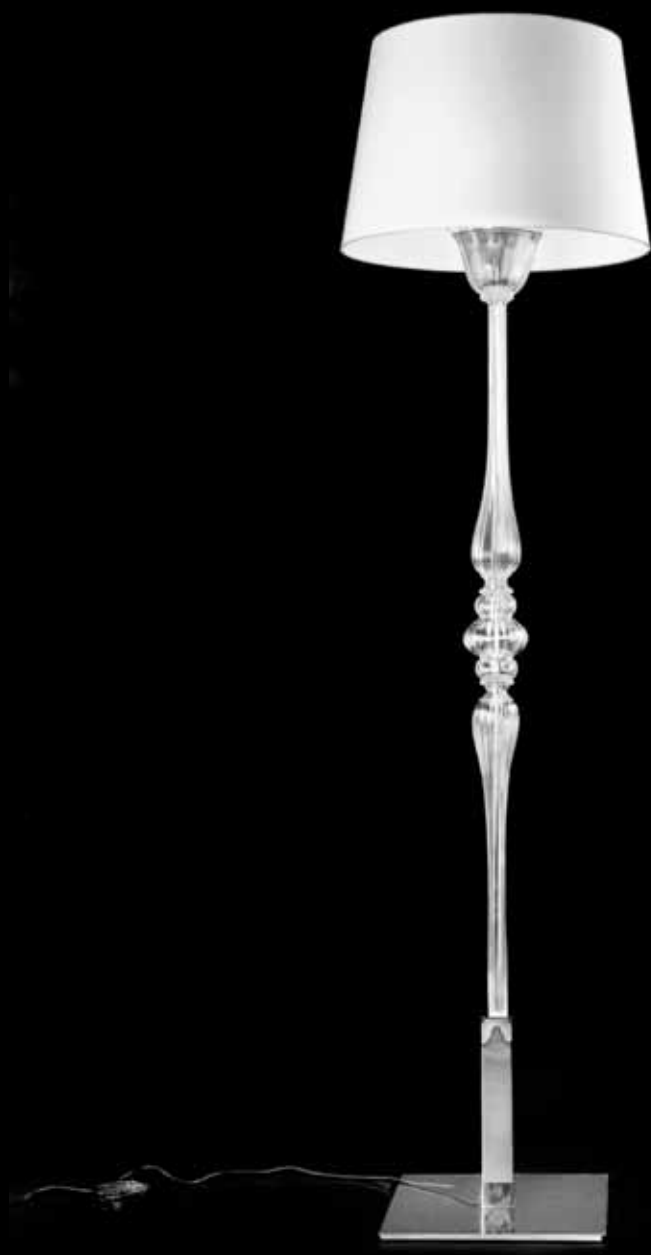
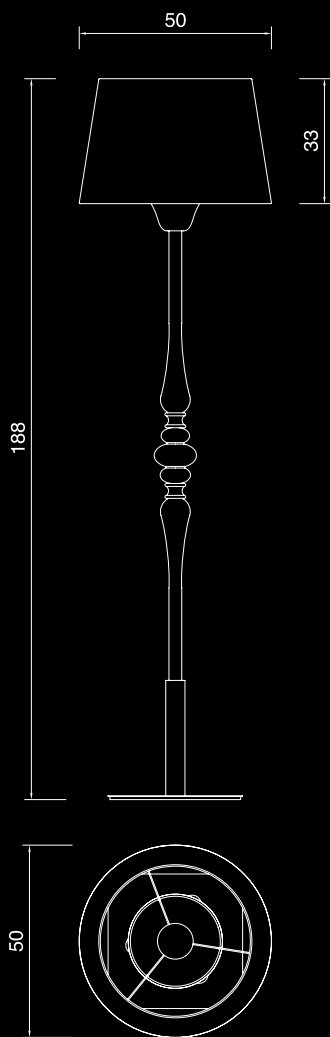

10000/TE

Piantana veneziana in vetro lavorato a mano
Struttura: metallo cromato
Colore vetro: cristallo
Paralume in tessuto: avorio, nero



Hand-crafted glass venetian floor lamp
Frame: polished chrome
Glass color: crystal
Fabric shades: ivory, black

Classe II

3 E14 x max 60W 230V + 1 E27 PAR x max 100W 230V



Energy saving



Carlotta

Designer: M & M

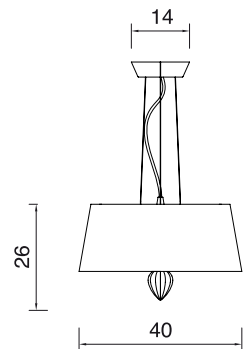

Sospensione con decoro in vetro lavorato a mano
Struttura: metallo cromato
Colore vetro: cristallo, ambra, rosso, nero
Paralume in tessuto: avorio, nero

10008/S3

Hanging lamp with hand-crafted glass decoration
Frame: chromed metal
Glass color: crystal, amber, red, black
Fabric shade: ivory, black

 Energy saving

 3 E27 x max 75W 230V Classe II

AVMazzega® s.r.l.

Via A. Vivarini, 3/B
30141 Murano, Venezia, Italy

T. +39 041 2737300 - 041 736677
F. +39 041 739939

Export departement
export@avmazzega.com

Commerciale Italia
venditeitalia@avmazzega.com

avmazzega@avmazzega.com
www.avmazzega.com